

## V 系列泵芯 Series-cartridge

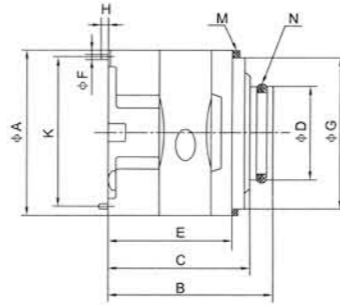

### 型号说明/Model Designation

(F3-)	PC-	25V	19	R	10
前注 Note	泵芯标志 Cartridge mark	系列号 Series	▲排量代号 Flow code	旋转方向 Rotation	设计号 Design number
无标记 No-marking: 石油系油 Petroleum series oil 乳化液 emulsification fluid 水-乙二醇 water glycol-fluid F3: 磷酸酯液 phosphate ester fluid	PC-单泵泵芯	20V	2, 3, 4, 5, 6, 7, 8, 9, 10, 11, 12, 14	(从泵的轴端看) (Viewed from shaft end of pump) L-逆时针旋转 Left hand for counter clockwise R-顺时针旋转 Right hand for clockwise	10
	双联泵轴端泵芯	25V	10, 12, 14, 15, 17, 19, 21, 25		
	Cartridge kit of single pump double pump shaft end	35V	21, 25, 30, 32, 35, 38, 45		
	PCT-双联泵盖端泵芯	45V	42, 45, 50, 57, 60, 66, 75		
	Cartridge kit of double pump cover end				

▲ 在1200r/min和0.69MPa(100psi)下的额定排量;与相应系列、规格的油泵性能参数一致,详见V系列单泵的性能参数。  
 USgpm Flow(USgpm) at 1200r/min and 0.69MPa.  
 The data of relevant series, model are unanimous. Please see V series-single pump data.

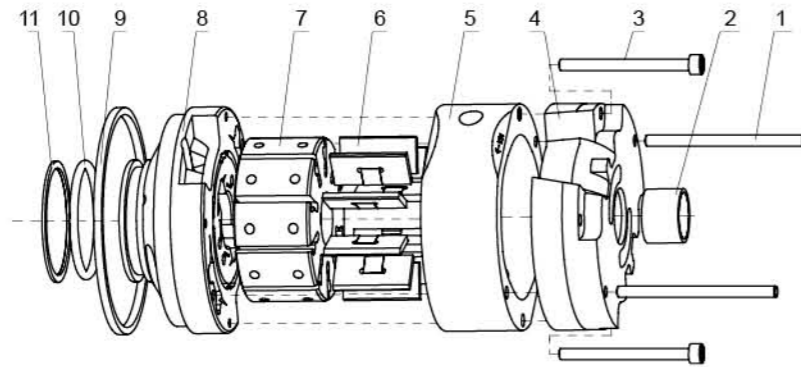

序号NO.	名称Part	数量Qty	序号NO.	名称Part	数量Qty	序号NO.	名称Part	数量Qty
1	销 Pin	2	5	定子 cam ring	1	9	挡圈 Retainer	1
2	滑动轴承 sliding bearing	1	6	叶片 vane kit	12	10	O型圈 O ring	1
3	十字槽盘头螺钉 cross pan head bolts	2	7	转子 Rotor	1	11	挡圈 Retainer	1
4	侧板 inlet support plate	1	8	压力侧板 outlet support plate	1			

系列号 Series	ØA	B	C	ØD	E	ØF	ØG	H	K	M (挡圈 Gasket)	M(O形圈 O-Ring)
20V	82.55	81.5	70.1	47	61.5	4.8	76.2	7	73.6	82.76x76.26x3.5	40x3.55
25V	96.8	98.8	87	52.2	71.2	4.8	90.5	7	88.19	97x91x3.5	44x3.53
35V	114.3	117.7	105	72.2	90.3	6.4	108	8	103.94	114.5x108.5x3.5	63.09x3.53
45V	133.35	141.1	129.6	80.2	105.5	6.4	127	8	123.8	133.6x127.6x3.5	71x3.55

转子内花键齿廓参数 Inside spline tooth outline parameter of rotor					
系列号 Series	齿数 Number of teeth	径节 Pitch	压力角 Pressure angle	大径 Major Diameter	小径 Minor Diameter
20V	30	48/96	45°	16.617	15.56
25V	40	48/96	45°	21.9	20.86
35V	37	40/80	45°	24.38	23.10
45V	14	12/24	30°	32.59	27.6

## VQ 系列叶片泵 Series-vane Pumps

### 产品简介/Product Introduction

适用于工程机械的高压高性能子母叶片泵。

主要特点为:

- 1、采用液压平衡的子母叶片结构及10叶片制的设计,压力更高,最高达到21MPa。
- 2、采用浮动侧板结构,可自动补偿端面间隙,使泵在高压下能保持较高的容积效率。
- 3、侧板采用双金属材料,提高了抗咬合性能,使泵的使用寿命更长。

The high-pressure and high-performance Intra-vane pumps for Mobile Equipment.

Features:

1. To adopt balanced hydraulic for the struction of Intra-vane and ten-Vane design, higher Pressure, top to 21 MPa.
2. To adopt floating structure for side plate, it will do a compensation for end-face clearance by automatic, so that even the pump under high pressure it can maintain a high volumetric efficiency.
3. The side plate is made of dual-metal material, it improved the seizure resistance. and so that the life of pump will be longer

## VQ 系列单泵 Series-single Pumps

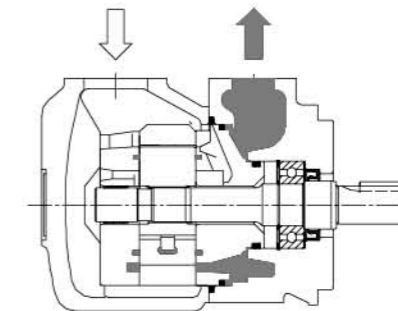

液压符号 Hydraulic Sign

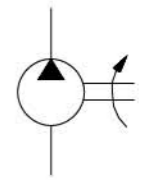

(F3-)	25VQ	19	A	(F)	-1	A	30	R
前注 Note	系列号 Series	▲排量代号 Flow code	油口连接 Port connections	安装形式 Installation type	轴伸形式 Shaft type	出口口位置 Outlet positions	设计号 Design number	旋转方向 Rotation
无标记 No-marking 石油系油 Petroleum series oil 乳化液 emulsification fluid 水-乙二醇 water glycol-fluid F3: 磷酸酯液 phosphate ester fluid	20VQ	2, 3, 4, 5, 6, 7, 8, 9, 10, 11, 12, 14	A-SAE 4 螺栓法兰 A-SAE 4 bolt flange	无标记 No-marking -法兰安装型 Flange Mounting F-脚座安装型 F-Foot Mounition	1平键轴/Str key 151花键轴/Spline	(从泵的盖端看) (Viewed from cover end of pump) A-进油口对面 Opposite inlet port B-从进油口逆时针90° 90° CCW from inlet C-进油口同侧 Inline with inlet D-从进油口顺时针90° 90° CW from inlet	30	(从泵的轴端看) (Viewed from shaft end of pump) R-顺时针旋转 right hand for clockwise L-逆时针旋转 left hand for counter-clockwise
	25VQ	10, 12, 14, 15, 17, 19, 21, 25			1平键轴/Str key 86重型平键轴 HD str key 11花键轴/Spline		20	
	35VQ	21, 25, 30, 32, 35, 38, 45						
	45VQ	42, 45, 50, 57, 60, 66, 75						

▲ 在1200r/min 和0.69MPa(100psi)下的额定排量  
 USgpm Flow(USgpm) at 1200r/min and 0.69MPa

技术参数/Technical Data

系列号 series	排量代号 Flow code (USgpm)	理论排量 Geometric displac- ement mL/r	最高使用压力 Max.operating pressure Mpa	最高转速 Max.speed r/min	最低转速 Min. speed r/min	
20VQ	2	7(0.43)	21	2700	600	
	3	10(0.61)				
	4	13(0.79)				
	5	16.5(1.01)				
	6	19(1.16)				
	7	22(1.40)				
	8	27(1.67)				
	9	30(1.85)				
	10	31.5(1.92)				
	11	35(2.14)				
	12	40(2.44)				16
	14	45(2.78)				14
25VQ	10	32(1.95)	21	2700	600	
	12	38(2.32)				
	14	43.5(2.65)				
	15	47(2.89)				
	17	54(3.30)				
	19	60(3.66)				
	21	67(4.13)		2500		
35VQ	21	67(4.13)	21	2500	600	
	25	81(4.94)				
	30	95(5.80)				
	32	101(6.16)				
	35	109(6.65)				
	38	119(7.26)				2400
	45	143(8.72)				14
45VQ	42	134(8.17)	17.5	2400	600	
	45	143(8.72)				
	50	159(9.70)				
	57	181(11.05)				
	60	189(11.53)				
	66	210(12.81)				
	75	237(14.46)		14		

20VQ 法兰安装尺寸  
Flange Mounting

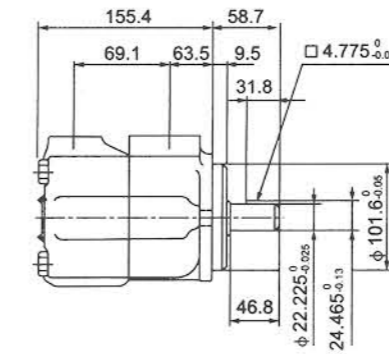
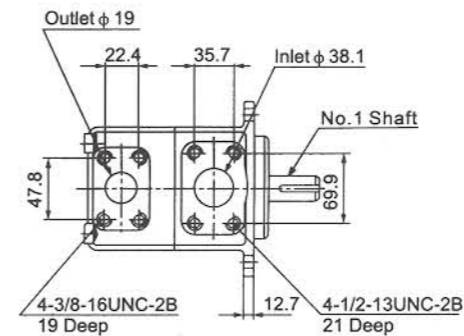

20VQ 脚座安装尺寸  
Foot Mounting

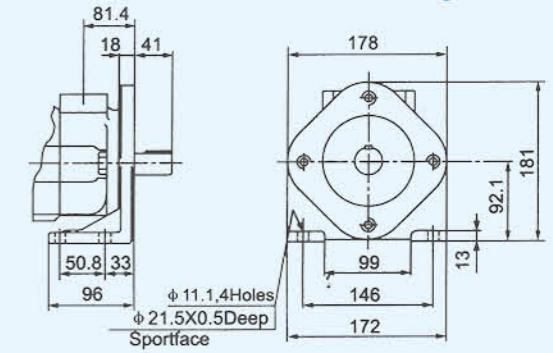

For other dimensions, refer to "Flange Mounting" type.

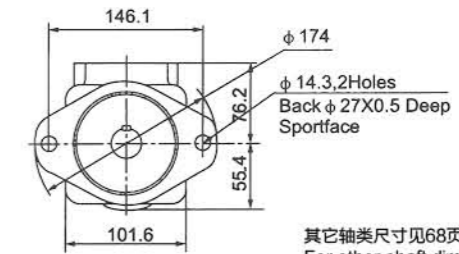

其它轴类尺寸见68页  
For other shaft dimensions, refer to page 68

25VQ 法兰安装尺寸  
Flange Mounting

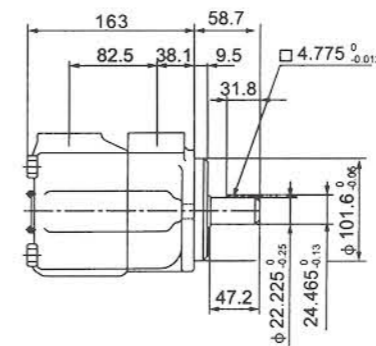
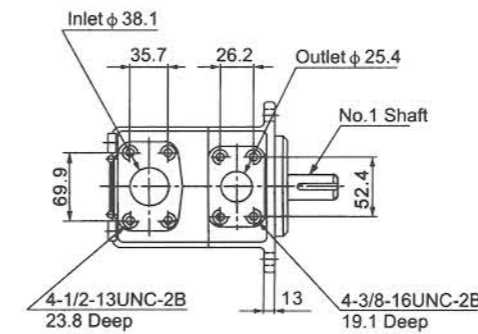

25VQ 脚座安装尺寸  
Foot Mounting

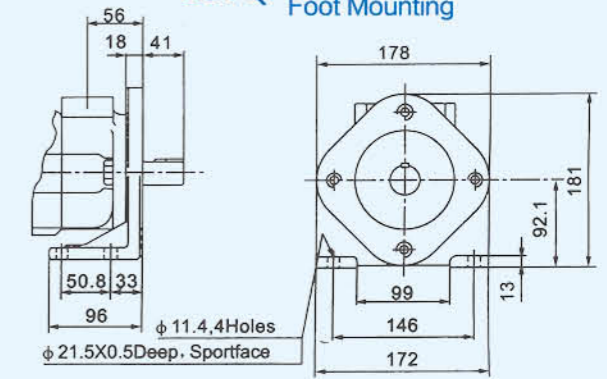

For other dimensions, refer to "Flange Mounting" type.

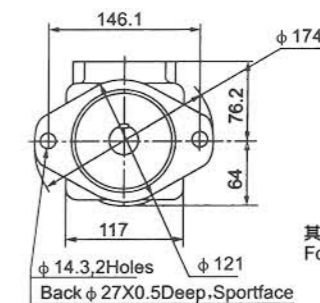

其它轴类尺寸见68页  
For other shaft dimensions, refer to page 68