

## V 系列单泵 Series-single Pumps

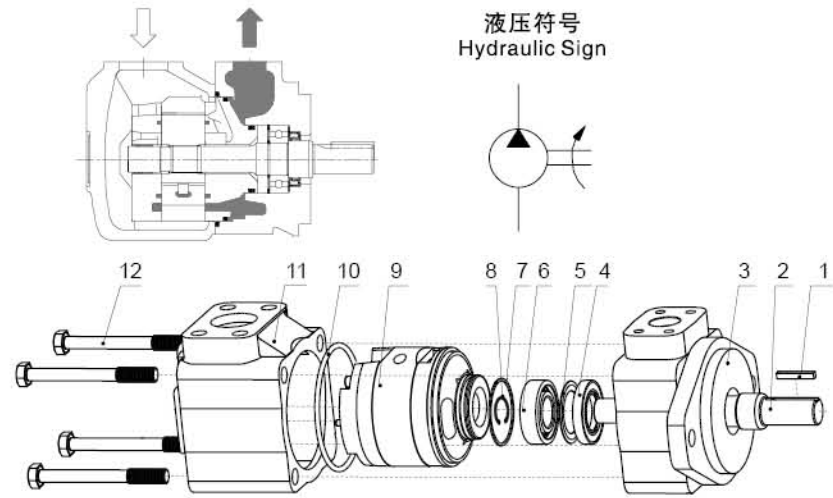

序号NO.	名称Part	数量Qty	序号NO.	名称Part	数量Qty	序号NO.	名称Part	数量Qty
1	平键straight key	1	5	垫片gasket	1	9	泵芯 cartridge	1
2	轴shaft	1	6	滚动轴承Ball bearing	1	10	O型圈O ring	1
3	前盖Front cover	1	7	叠形挡圈pile type retainer	1	11	后盖Rear cover	1
4	油封shaft seal	1	8	轴用弹性挡圈cir clip for shaft	1	12	六角头螺栓hexagon headed bolt	4

适用于塑胶机械、鞋革机械、机床、压铸及冶金设备的高性能子母叶片泵。

主要特点为:

- 1、采用子母叶片及施压平衡的结构，减少了叶片对定子的压力，其性能更稳定，寿命更长。
- 2、12叶片制减小了流量脉动的振幅，系统噪声特性低。
- 3、多排量、多轴伸及进出油口四种不同的相对位置，使用户使用更灵活。
- 4、泵芯的插装式结构，现场维修更方便。

High Performance Intravane Pumps for plastic injection machinery, Shoe machinery, Tool machinery, Die casting machinery and Metal I urge equipment.

Features

1. Intravane pumps with hydraulic balancing structure provide more stable performance and longer life since less pressure from vane on stator.
2. Twelve vane system provide low amplitude flow pulsation resulting in low system noise characteristics.
3. Various displacement and shafts with 4 different outlet opposite position make operation more flexible.
4. The cartridge is independent of the drive shaft, allowing for easy servicing without remove the pump from its mounting.

### 型号说明/Model Designation

(F3-)	25V	19	A	-1	A	22	R
前注 Note	系列号 Series	▲排量代号 Flow code	油口连接 Port connections	轴伸形式 Shaft type	出口口位置 Outlet positions	设计号 Design number	旋转方向 Rotation
无标记 No-marking: 石油系油 Petroleum series oil 乳化液 emulsification fluid 水-乙二醇 water glycol-fluid F3: 磷酸酯液 phosphate ester fluid	20V	2, 3, 4, 5, 6, 7, 8, 9, 10, 11, 12, 14	A-SAE 4螺栓法兰 4-bolt flange	1-平键轴 Str key 151-花键轴 Spline	(从泵的盖端看) (Viewed from cover end of pump) A-进油口对面 Opposite inlet B-从进油口逆时针90° 90° CCW from inlet C-进油口同侧 Inline with inlet D-从进油口顺时针90° 90° CW from inlet	22	(从泵的轴端看) (Viewed from shaft end of pump) R-顺时针旋转 right hand for clockwise L-逆时针旋转 left hand for counter-clockwise
	25V	10, 12, 14, 15, 17, 19, 21, 25		1-平键轴 Str key 86-重型平键轴 HD Str key 11-花键轴 Spline			
	35V	21, 25, 30, 32, 35, 38, 45					
	45V	42, 45, 50, 57, 60, 66, 75					

▲ 在1200r/min 和0.69MPa(100psi)下的额定排量  
USgpm Flow(USgpm) at 1200r/min and 0.69MPa

### 技术参数/Technical Data

系列号 series	排量代号 Flow code (USgpm)	理论排量 Geometric displacement mL/r(in <sup>3</sup> /r)	使用抗磨液压油或磷酸酯 With antiwear hydraulic oil ri phosphate ester fluid		使用水-乙二醇 With water glycol fluid		使用油包水乳化液 With water-oil emulsions		最低转速 Min. speed						
			最高使用压力 Max.operating pressure MPa	最高转速 Max.speed r/min	最高使用压力 Max.operating pressure MPa	最高转速 Max.speed r/min	最高使用压力 Max.operating pressure MPa	最高转速 Max.speed r/min							
20V	2	7.5(0.46)	13.8	1800	13.8	1500	6.9	1200	600						
	3	10(0.61)													
	4	13(0.79)													
	5	16.5(1.01)													
	6	19(1.16)													
	7	23(1.40)													
	8	27(1.67)	20.7	1800	15.9	1500	6.9	1200							
	9	30(1.85)													
	10	32(1.95)													
	11	36(2.20)													
	12	40(2.44)	15.9	1800	13.8	1500	6.9	1200							
	14	45(2.78)													
	15	47(2.89)													
	25V	10	32.5(1.98)	17.2	1800	15.9	1500	6.9		1500	600				
12		39(2.38)													
14		45(2.78)													
15		47(2.89)													
17		55(3.36)													
19		60(3.66)													
21		67(4.13)													
25	81(4.94)														
35V	21	67(4.13)	17.2	1800	15.9	1500	6.9	1500	600						
	25	81(4.94)													
	30	97(5.91)													
	32	101(6.16)													
	35	112(6.83)													
	38	121(7.37)													
	45	147(8.95)								13.8	1800	15.9	1500	6.9	1500
42	138(8.41)														
45V	45	147(8.95)	17.2	1800	15.9	1500	6.9	1500	600						
	50	162(9.85)													
	57	181(11.05)													
	60	193(11.75)													
	66	212(12.93)													
	75	237(14.46)								13.8	1800	15.9	1500	6.9	1500
	42	138(8.41)													



安装连接尺寸 Installation Dimensions

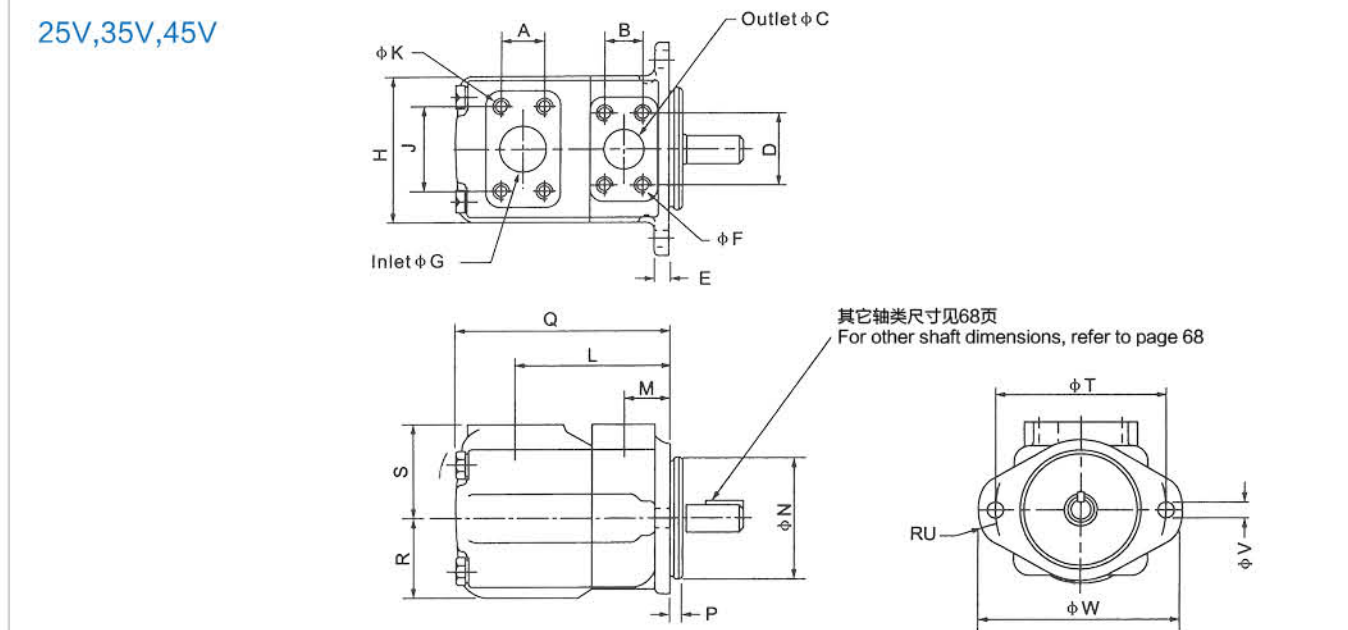
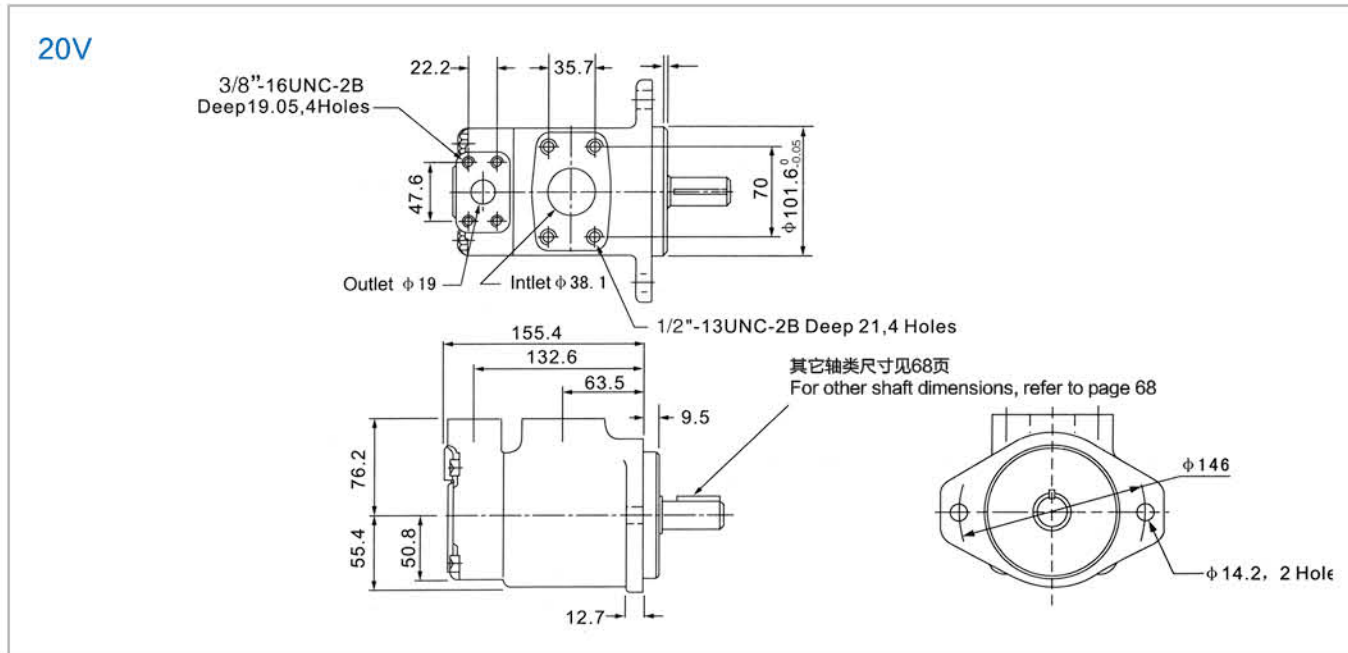

型号 Model	A	B	ØC	D	E	ØG	H	J	L	M	N	P	Q	R
25V	35.7	26.2	25.4	52.4	12.7	38.1	118	69.9	121	38.1	101.60/101.55	9.53	162.1	63.5
35V	42.9	30.2	31.8	58.7	16	50.8	140	77.8	125.5	38.1	127.00/126.95	9.53	185	69.9
45V	61.9	35.7	38.1	69.9	16	76.2	159	106.4	153	43	127.00/126.95	12.7	216	82.6
型号 Model	S	T	RU	ØV	W	ØX	ØFX螺纹深度,4孔 ØFx full thread depth, 4 holes		ØKX螺纹深度,4孔 ØKx full thread depth, 4 holes					
25V	76.2	146	14	14.2	175	121	3/8-16UNC-2BX19.1		1/2-13UNC-2BX23.8					
35V	82.6	181	16	17.5	213	148	7/16-14UNC-2BX22.3		1/2-13UNC-2BX22.3					
45V	93.7	181	16	17.5	213	148	1/2-13UNC-2BX23.8		5/8-11UNC-2BX25.4					

**V 系列双联泵**  
Series-double Pumps

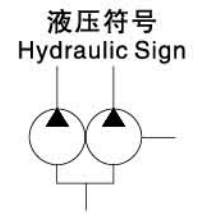
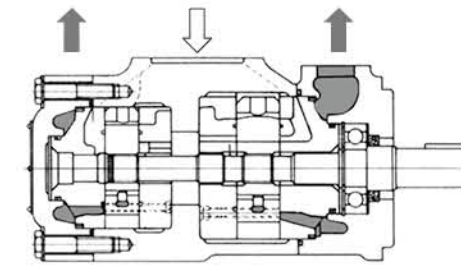

型号说明/Model Designation

(F3-)	3525V	38	A	17	-1	AB	22	R
前注 Note	系列号 Series	▲轴端泵排量代号 Flow-Shaft end code	油口连接 Port connections	▲盖端泵排量代号 Flow-Cover end code	轴伸形式 Shaft type	出油口位置 Outlet positions	设计号 Design number	旋转方向 Rotation
无标记 No-marking:	2520V	10, 12, 14, 15, 17, 19, 21, 25	A-SAE 4螺栓法兰 4-bolt flange	2, 3, 4, 5, 6, 7, 8, 9, 10, 11, 12, 14	1-平键轴 Str key 86-重型平键轴 HD Str key 11-花键轴 Spline	见下表 See below	22	(从泵的轴端看) (Viewed from shaft end of pump) R-顺时针旋转 right hand for clockwise L-逆时针旋转 left hand for counter-clockwise
石油系油 Petroleum series oil	3520V	21, 25, 30, 32, 35, 38, 45		2, 3, 4, 5, 6, 7, 8, 9, 10, 11, 12, 14				
乳化液 emulsification fluid	3525V	21, 25, 30, 32, 35, 38, 45		10, 12, 14, 15, 17, 19, 21, 25				
水-乙二醇 水-glycol-fluid	4520V	42, 45, 50, 57, 60, 66, 75		2, 3, 4, 5, 6, 7, 8, 9, 10, 11, 12, 14				
F3: 磷酸酯液 phosphate ester fluid	4525V	42, 45, 50, 57, 60, 66, 75		10, 12, 14, 15, 17, 19, 21, 25				
	4535V	42, 45, 50, 57, 60, 66, 75		21, 25, 30, 32, 35, 38, 45				

▲ 在1200r/min和0.69MPa(100psi)下的额定排量  
USgpm Flow(USgpm) at 1200r/min and 0.69MPa

出油口位置 (从泵的盖端看)

Outlet Positions (Viewed from cover end of pump)

出油口位置 Outlet positions	除4535V外的所有系列 All series except 4535V	4535V
第一出油口 在进油口对面 No.1 outlet opposite inlet	AA 第二出油口在进油口逆时针转135° No.2 outlet 135° CCW from inlet	第二出油口在进油口对面 No.2 outlet opposite inlet
	AB 第二出油口在进油口逆时针转45° No.2 outlet 45° CCW from inlet	第二出油口在进油口逆时针转90° No.2 outlet 90° CCW from inlet
	AC 第二出油口在进油口顺时针转45° No.2 outlet 45° CW from inlet	第二出油口在进油口同侧 No.2 outlet inline with inlet
	AD 第二出油口在进油口顺时针转135° No.2 outlet 135° CW from inlet	第二出油口在进油口顺时针转90° No.2 outlet 90° CW from inlet
第一出油口 从进油口 逆时针转90° No.1 outlet 90° CCW from inlet	BA 第二出油口在进油口逆时针转135° No.2 outlet 135° CCW from inlet	第二出油口在进油口对面 No.2 outlet opposite inlet
	BB 第二出油口在进油口逆时针转45° No.2 outlet 45° CCW from inlet	第二出油口在进油口逆时针转90° No.2 outlet 90° CCW from inlet
	BC 第二出油口在进油口顺时针转45° No.2 outlet 45° CW from inlet	第二出油口在进油口同侧 No.2 outlet inline with inlet
	BD 第二出油口在进油口顺时针转135° No.2 outlet 135° CW from inlet	第二出油口在进油口顺时针转90° No.2 outlet 90° CW from inlet

